

Goodrive300L Series

Elevator AC Drive



Introduction..... 2

Features..... 3

Safety 3

Comfort 3

Ease of use 3

Type designation key..... 5

Specifications..... 6

Standard wiring diagram..... 8

Options 9

PG card 9

I/O expansion card 11

STO card 11

Battery rescue device for emergency running 12

AC reactor..... 12

Filter..... 12

Braking unit and resistor..... 13

Installation dimensions 13

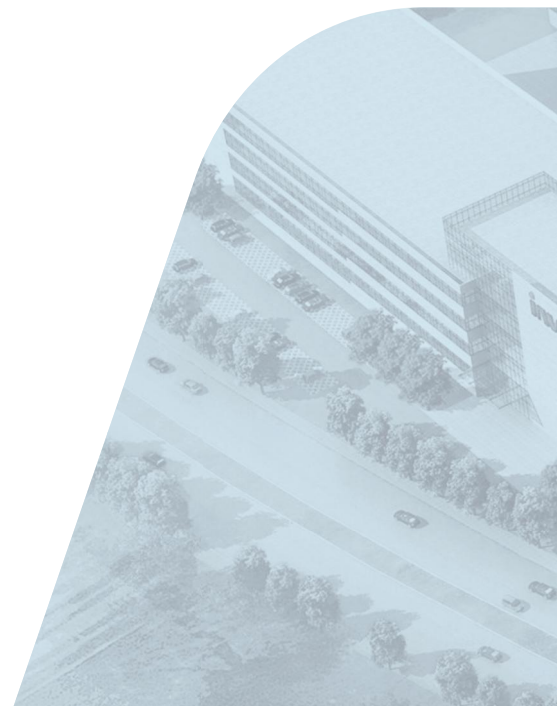
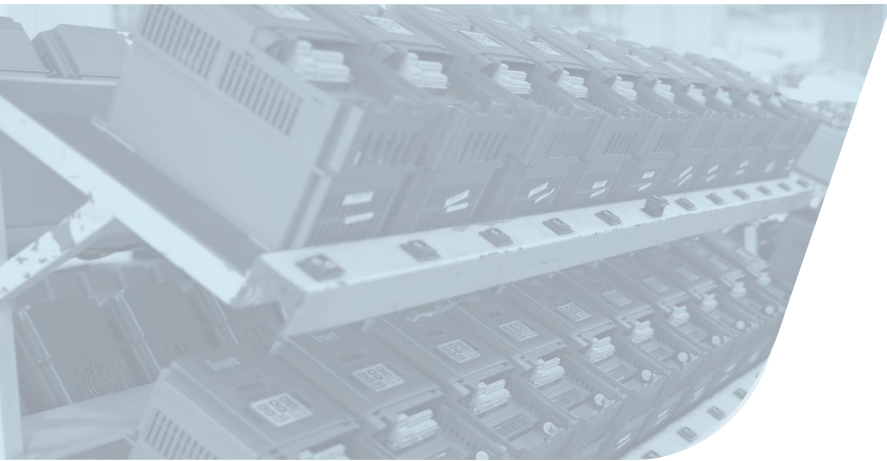



Introduction

Goodrive300L series elevator AC drives are the new generation AC drives developed based on INVT the latest and most advanced Goodrive300 control platform. As using TI 28-series DSP and advanced vector control technology, Goodrive300L series elevator AC drives improved great achievements in security, reliability, control performance and use functions.

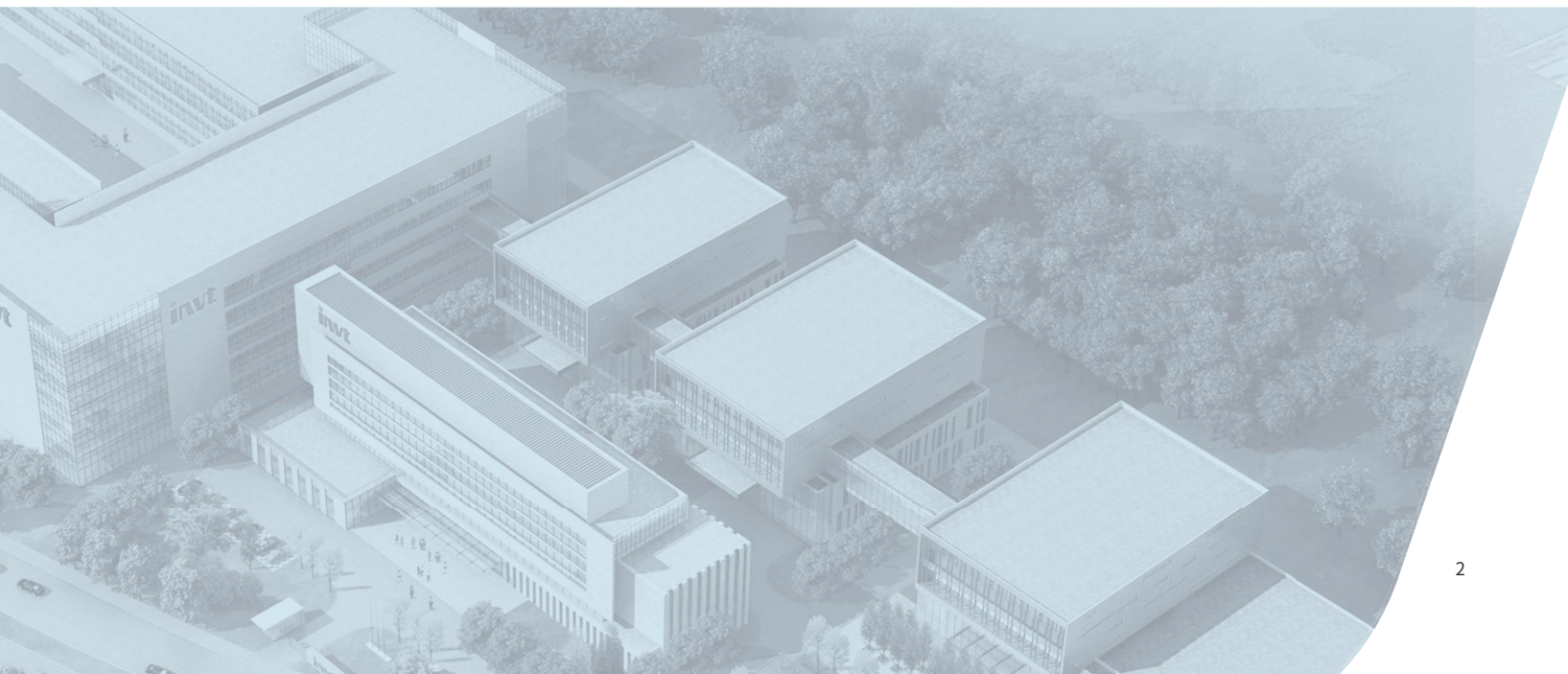

Features

Safety

- **Safe Torque Off (STO)**

Support optional Built-in Safety Torque Off function, and conform to the standard and grade as follows:

Standard and grade					
IEC 61508		EN/ISO 13849-1		EN954-1	
SIL	3	PL	e	Category	3

- **Forced deceleration**

Prevent the lift from soaring to the top or diving to the bottom during the upward or downward running.

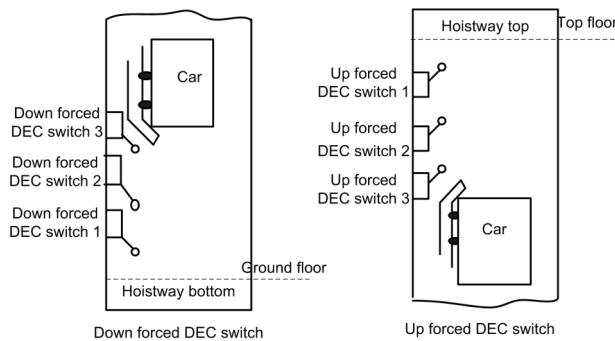

- **Emergency running**

When the AC power fails, the control system connects the UPS (voltage $\geq 300V$) or battery ($48V \leq \text{voltage} \leq 96V$) to the main circuit terminals (+) and (-) of the AC drive by the bypass switch. The AC drive implements automatic adjacent levelling and shutdown after receiving the emergency running speed and running direction commands (FWD/REV).

Note: When using the emergency running function, battery rescue device need to be selected (Refer to page 12 for details).

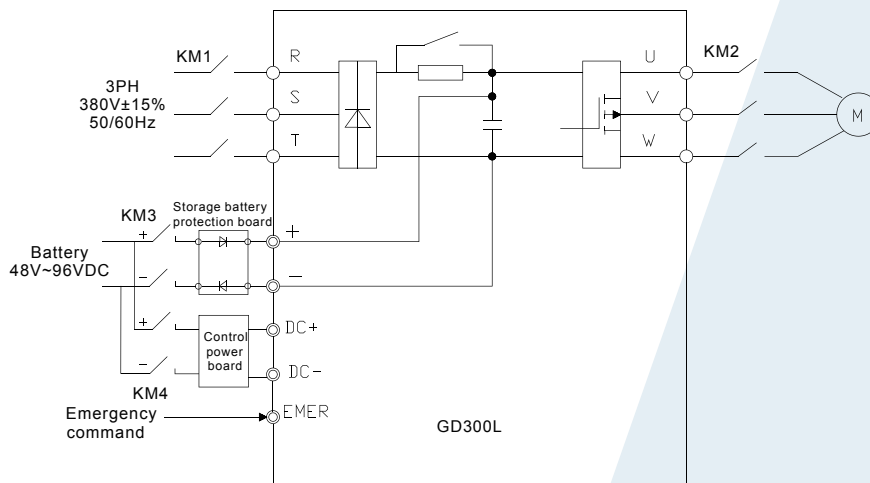

Wiring diagram of using battery (48V~96VDC) as emergency power

- **Brake and contactor control**

Control the contactor and brake based on lift running logic, enhancing lift safety performance.

Comfort

- **Starting torque compensation with weight sensors**

Prevent reverse slip at startup by parameter setting, ensuring stable lift startup.

- **Starting torque compensation without weight sensors**

Implement precise control on the gearless synchronous-tractor lifts, achieving stable startup and improving comfort.

- **ACC/DEC S curve algorithm**

Improve comfort during motor ACC, DEC, and stop. A great parameter value corresponds to a steep S curve, while a small parameter value corresponds to a smooth S curve.

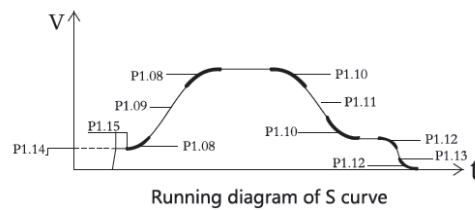

- **Optimized ASR**

Use variable proportional and integral gain control, providing quick dynamic response in startup and stop states and improving comfort during constant-speed running.

Ease of use

- **Ability to drive asynchronous and synchronous motors**

Can drive asynchronous or synchronous motors when the elevator working lower than 4m/s

- **Support open loop control mode without encoder and closed loop control mode with encoder**

- **Static identification on the initial pole angle of a synchronous motor**

Execute autotune for the permanent magnetic synchronous motor in static mode without load, simplifying commissioning.

- **Support multiple types of encoder**

Support incremental, SIN/COS, absolute, and UVW encoders.

- **Energy-saving running mode**

Support the use of RBU, implementing energy-saving running.

- **Monitor and control by upper computer software**

Allow the upper computer software--INVT Studio to monitor and control the status and debug parameters in real time through Modbus communication.

- **Optional LCD keypad**

Include two types of LCD keypads: English-Chinese bilingual LCD keypad and English-Turkish bilingual LCD keypad

Type designation key

GD300L - 5R5G - 4 - LIFT

①

②

③

④

Type designation rules

Key	Sign	Description	Remarks
Abbreviation	①	Product series abbreviation	GD300L is short for Goodrive300-LIFT
Rated power	②	Power range + Load type	5R5—5.5kW G—Constant torque load
Voltage degree	③	Voltage degree	S2: AC 1PH 220V(-15%)~240V(+10%) 4: AC 3PH 380V(-15%)~440V(+10%)
No. for market management	④	Number for market management	LIFT: AC drive special for lifts(ignorable)

Rated specifications

Model	Rated output power (kW)	Rated input current (A)	Rated output current (A)	DC reactor	Braking unit
GD300L-2R2G-S2	2.2	23	10	Optional (external)	Standard (embedded)
GD300L-004G-4	4	13.5	9.5		
GD300L-5R5G-4	5.5	19.5	14		
GD300L-7R5G-4	7.5	25	18.5		
GD300L-011G-4	11	32	25		
GD300L-015G-4	15	40	32		
GD300L-018G-4	18.5	47	38	Standard (embedded)	Optional (external)
GD300L-022G-4	22	56	45		
GD300L-030G-4	30	70	60		

Note: If you equip other models, please contact INVT

Specifications

Function		Specifications
Power input	Input voltage (V)	AC 1PH 220V(-15%)~240V(+10%) AC 3PH 380V(-15%)~440V(+10%)
	Input current (A)	Refer to the rated value.
	Input frequency (Hz)	50Hz or 60Hz Allowed range: 47~63Hz
Power output	Output voltage (V)	0~input voltage
	Output current (A)	Refer to the rated value.
	Output power (kW)	Refer to the rated value.
	Output frequency (Hz)	0~400Hz
Technical control	Control mode	V/F, sensorless vector control, and sensor-included vector control
	Motor type	Asynchronous motor and permanent magnet synchronous motor
	Adjustable-speed ratio	For open-loop vector control: 1:200 For closed-loop vector control: 1:1500
	Speed control accuracy	± 0.5%(open-loop vector); ± 0.05% (closed-loop vector)
	Speed fluctuation	± 0.3% (sensorless vector control)
	Torque response	<20ms (sensorless vector control)
	Torque control accuracy	10% (sensorless vector control)
	Starting torque	0.3Hz/150% (asynchronous-motor sensorless vector control) 0 Hz/200% (sensor-included vector control)
Running control	Overload capability	150% of rated current: 1 minute 180% of rated current: 10 seconds 200% of rated current: 1 second
	Frequency setting method	Digital setting, analog setting, multi-step speed running setting, and MODBUS communication setting, which implement switching between setting channels
	Voltage auto-adjustment	Constant voltage automatically kept when the grid voltage transients
	Fault protection	More than 30 fault protection functions against faults such as over current, overvoltage, undervoltage, overheating, phase loss and overload

Function		Specifications
Peripheral interface	Analog input	1 input (AI1): 0~10V/0~20mA
	Analog output	1 output (AO1): 0~10V /0~20mA
	Digital input	8 common inputs; Max. frequency: 1kHz; internal impedance: 3.3kΩ; 1 high speed input; Max. frequency: 50kHz Resolution: ≤2ms
	Digital output	1 terminal Y for open collector output
	Relay output	3 NO programmable relay outputs RO1A NO, RO1C common terminal RO2A NO, RO2C common terminal RO3A NO, RO3C common terminal Contactor capability: 3A/AC250V, 1A/DC30V
	Power output	24V/200mA and 10V/50mA power output
	PG expansion card (optional)	Incremental 5~24V ; SIN/COS; absolute value; UVW
	I/O expansion cards (optional)	3 for common digital input 1 for analog input AI2 1 for NO/NC relay output 1 for HDO output 1 for Y output 1 for RS-485 interface (supporting RTU)
	STO expansion card (optional)	Provides STO security terminal functions.
	Bluetooth/Ethernet expansion card (optional)	Commissions devices through Bluetooth or Ethernet communication.
Others	Mountable method	Wall
	Running environment temperature	-10~50°C. The inverter must be derated if temperature is above 40°C.
	MTBF	10 years
	Protective degree	IP20
	Cooling	Forced air cooling
	Braking unit	Built-in: ≤15kW; optional for others
	DC reactor	Standard configuration: ≥18.5kW
	EMC filter	Optional filters C2 can be configured, meeting IEC618000-3 C2 requirements.

Standard wiring diagram

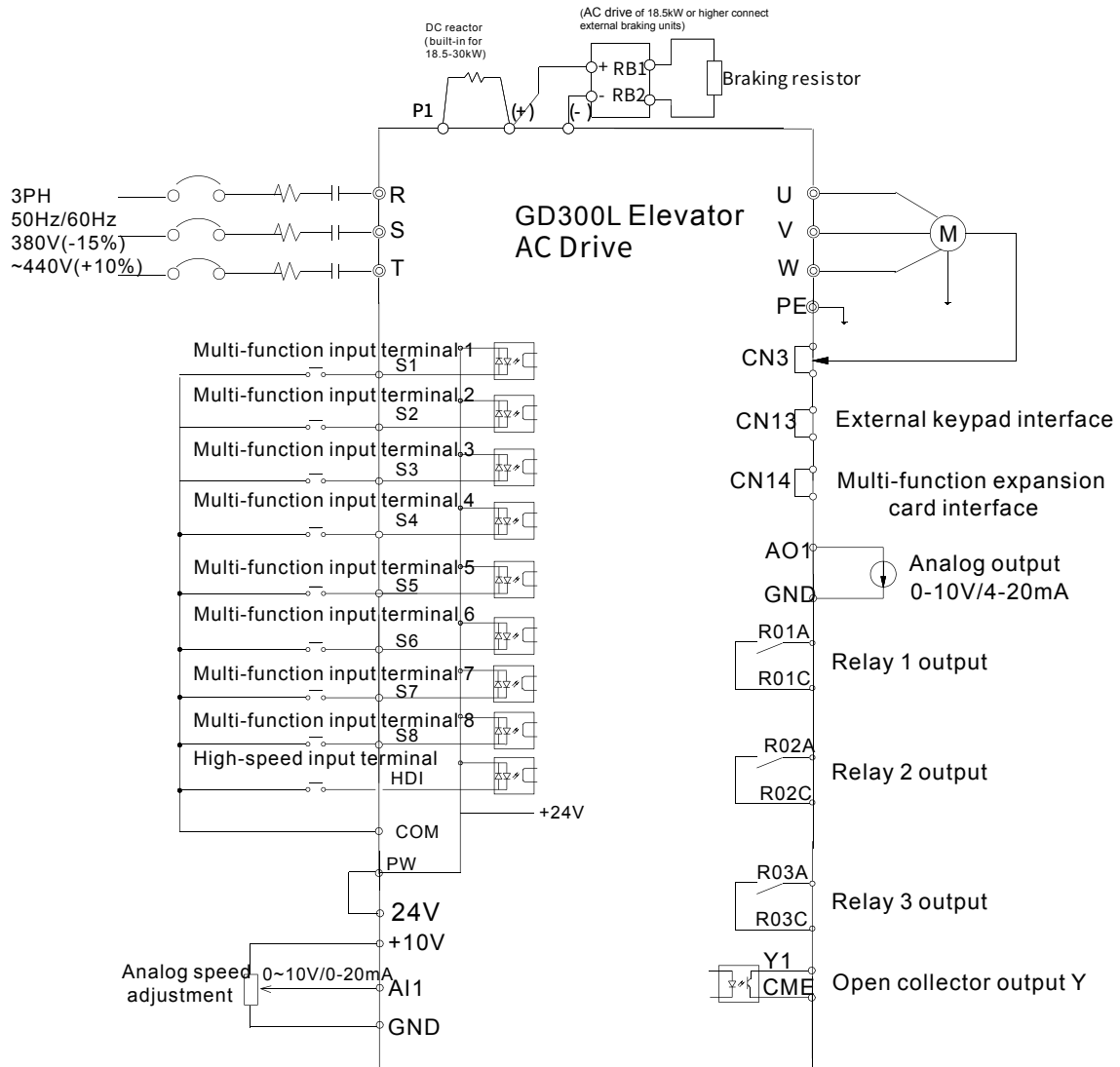

Options

PG card

Incremental Encoder PG card: EC-PG101-05/EC-PG101-12/EC-PG101-24

The Incremental Encoder PG card can be divided into three kinds according to the voltage of power: 5V, 12V and 24V, corresponding to the input voltage range respectively is: 4.75~7V、11.75~16V、24V±5%.

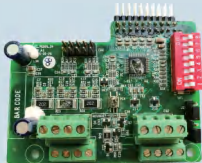
	Signal name	Description
	PWR, COM1	Power supply terminals
	IA+, IA-, IB+, IB-, IZ+, IZ-	Encoder signal input terminals. Support the input of the A, B, and Z signals from differential, open collectrand pull-push encoders. Voltage range: 12~15V Input frequency: 0~100kHz
	OA+, OA- OB+, OB-	5V differential frequency-division output terminals. Output frequency: 0~80kHz Output impedance: 70 ohm Frequency division range: 1~256
	OA, OB	Output terminals of frequency-division push-pull signals and open-collector signals. (J1 and J2 are used to select the output signal mode.) Output frequency: 0~80kHz Output impedance: 70 ohm Frequency division range: 1~256

SIN/COS Encoder PG card: EC-PG102-05 (DB15 Pin connector type\Terminal type)

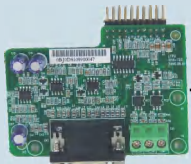
	Signal name	Terminal identifier	Description
	A+	8	Encoder signal input terminals. Voltage range: 0.8~1.2V Input range: 0~200kHz
	A-	3	
	B+	9	
	B-	4	
	C+	6	
	C-	1	
	D+	7	
	D-	2	
	R+	15	Voltage range: 0.2~0.85V
	R-	14	Input range: 0~200kHz
	5V	12	Encoder power: 5V±5%
	0V	13	Max. output current: 300mA

UVW Encoder PG card: EC-PG103-05 (DB15 Pin connector type\Terminal type)

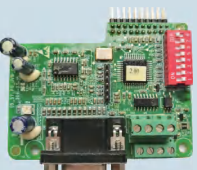
	Signal name	Terminal identifier	Description
	A+	8	Encoder differential signal input terminals. Input range: 0~100kHz
	A-	3	
	B+	9	
	B-	4	
	Z+	15	
	Z-	14	
	U+	6	Encoder angle signal input terminals. Input range: 0~100kHz
	U-	1	
	V+	7	
	V-	2	
	W+	10	
	W-	5	
	5V	12	Encoder power: 5V±5% Max. output current: 300mA
	0V	13	

Absolute Encoder PG card: EC-PG106-05 (DB15 Pin connector type\Terminal type)

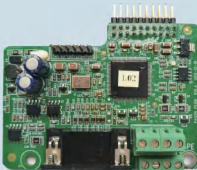
	Signal name	Terminal identifier	Description
	A+	1	Encoder sine signal input terminals. Input range: 0~50kHz
	A-	2	
	B+	3	
	B-	4	
	DATA+	5	Encoder position signal input terminals. Input range: 0~50kHz
	DATA-	6	
	CLK+	11	Clock signal input terminals.
	CLK-	12	
	PWR	13	Encoder power: 5V±5% Max. output current: 300mA
	GND	14	

Note: DB15 pin connector type and terminal type are optional for all PG card except incremental encoder PG card.

I/O expansion card

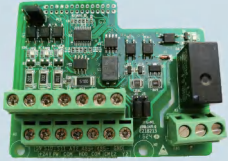
	Signal name	Description
	S9~S11	Digital input terminals, working with PW and COM to generate optical coupling isolation input Input voltage range: 9~30V Input impedance:3.3kΩ
	HDO	High-speed output terminal
	+24V	24V power supply
	PW	External power input terminal
	COM	Common terminal of +24V or external power supply
	GND	Reference zero potential of +10V
	Y2, CME2	Open collector output terminal, corresponding to common terminal CME2 External voltage range: 0~24V Output current range: 0~50mA
	AI2	Analog input terminal Output range: 0~10V/0~20mA (switched by J3)
	RO4A, RO4B, RO4C	Relay output: RO4A common; RO4B NC; RO4C NO Contact capacity: AC250V/3A, DC30V/1A
	RS485+ /RS485-	RS485 serial port communication terminals, supporting Modbus RTU

STO card

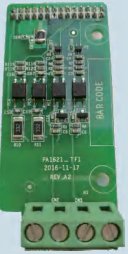
	Signal name	Terminal identifier	Description
	H1, 24V	STO input 1	STO redundant input terminals, externally connecting to the NC contactor If the, the response time from STO switch act to disconnect output of the inverter is less than 50 milliseconds. The length of cable must be within 30 meters for secure. If STO is disabled, H1 and H2 can be used as S5 and S6—the digital input terminals for extended.
	H2, 24V	STO input 2	

Battery rescue device for emergency running

When using battery (48V~96VDC) as emergency power, battery rescue device is needed. It is space-saving and convenient to fix due to the integration of battery protection board and boost power board.

	Parts	Function
	Battery protection board	Installed diodes(D1 and D2) to protect the storage battery
	Boots power board	Boost the voltage from the battery to power the emergency operation.

AC reactor

Inverter model	Input AC reactor	Output AC reactor
GD300L-004G-4	GDL-ACL0014-4CU	GDL-OCL0010-4CU
GD300L-5R5G-4	GDL-ACL0020-4CU	GDL-OCL0014-4CU
GD300L-7R5G-4	GDL-ACL0025-4CU	GDL-OCL0020-4CU
GD300L-011G-4	GDL-ACL0035-4AL	GDL-OCL0025-4CU
GD300L-015G-4	GDL-ACL0040-4AL	GDL-OCL0035-4AL
GD300L-018G-4	GDL-ACL0051-4AL	GDL-OCL0040-4AL
GD300L-022G-4	GDL-ACL0051-4AL	GDL-OCL0050-4AL
GD300L-030G-4	GDL-ACL0070-4AL	GDL-OCL0060-4AL

Filter

GD300L support the following optional filters, which meet EMI C2 requirement.

Inverter model	Input AC reactor	Output AC reactor
GD300L-2R2G-S2	FLT-P04016L-B	FLT-L04016L-B
GD300L-004G-4		
GD300L-5R5G-4		
GD300L-7R5G-4	FLT-P04032L-B	FLT-L04032L-B
GD300L-011G-4		
GD300L-015G-4		
GD300L-018G-4	FLT-P04045L-B	FLT-L04045L-B
GD300L-022G-4		
GD300L-030G-4		
	FLT-P04065L-B	FLT-L04065L-B

Braking unit and resistor

AC Drive model	Braking unit model	Min. braking resistor(Ω)	Recommended braking resistor(Ω)	Recommended resistor power(W)
GD300L-004G-4	Embedded	80	120	1200
GD300L-5R5G-4		60	80	1500
GD300L-7R5G-4		50	60	2000
GD300L-011G-4		35	40	3000
GD300L-015G-4		30	32	4500
GD300L-018G-4	DBU-055-4	25	28	5000
GD300L-022G-4		20	22	6000
GD300L-030G-4		16	20	10000

Installation dimensions

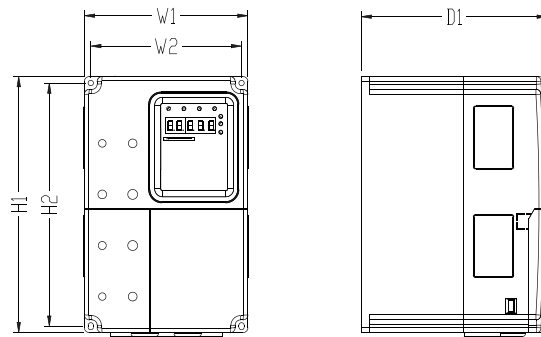

Wall mounting diagram for 1.5 kW~15 kW inverters

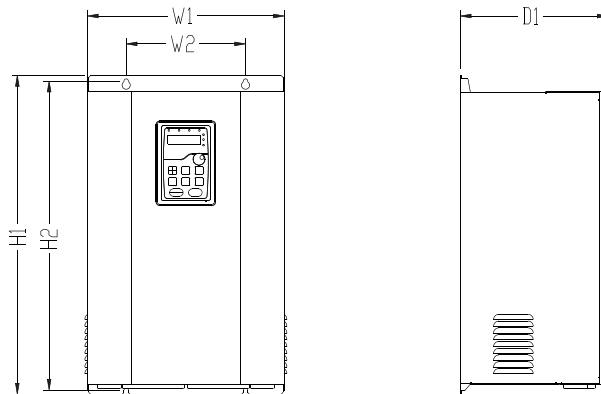

Wall mounting diagram for 18.5 kW~30 kW inverters

Wall-mounting dimensions for 380V inverters (unit: mm)

Model	W1	W2	H1	H2	D1	Installation hole (d)
1.5kW~5.5kW	160	147.5	250	237.5	175	5
7.5kW~15kW	220	206	320	305.5	180	6
18.5kW~30kW	290	176	470	455.5	220	6.5

Your Trusted Industry Automation Solution Provider

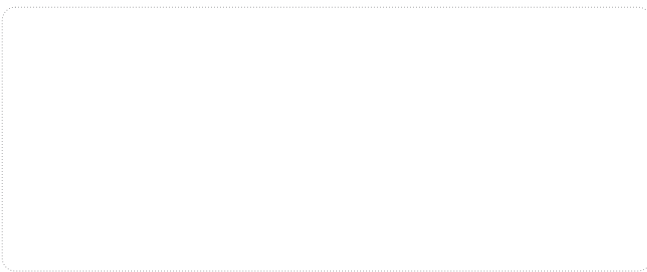

E-mail: overseas@invt.com.cn

Website: www.invt.com

SHENZHEN INVT ELECTRIC CO.,LTD. INVT Guangming Technology Building, Songbai Road, Matian, Guangming District, Shenzhen, China

- Industrial Automation:**
- HMI
 - PLC
 - VFD
 - Servo System
 - Elevator Intelligent Control System
 - Rail Transit Traction System
- Electric Power:**
- UPS
 - DCIM
 - Solar Inverter
 - New Energy Vehicle Powertrain System
 - New Energy Vehicle Charging System
 - New Energy Vehicle Motor

INVT Copyright.
Information may be subject to change without notice during product improving.

66003-00186

202407(V4.0)